

# Installation & Maintenance Instructions

2-WAY DIRECT-ACTING SOLENOID VALVES  
NORMALLY CLOSED OPERATION — 3/4", 1", OR 1 1/4" NPT  
FUEL GAS SERVICE

SERIES

8040

8041

Form No.V6058R4

**NOTICE:** See separate solenoid installation and maintenance instructions for information on: **Wiring, Solenoid Temperature, Causes of Improper Operation and Coil Replacement.**

## DESCRIPTION

Series 8040 valves are 2-way normally closed direct-acting solenoid valves designed for fuel gas service. Valve bodies are made of rugged aluminum with trim and internal parts made of steel and stainless steel. Series 8040 valves are provided with a general purpose solenoid enclosure.

Series 8041 or EF8040 valves are the same as Series 8040 except they are provided with an explosionproof/watertight solenoid enclosure.

## Provisions for Pressure and Seat Leakage

### Testing (See Figure 1.)

Series 8040 valves are provided with four 1/8" tapped and plugged holes, two on either side of valve body. Two upstream for pressure testing; two downstream for seat leakage testing. Leakage testing frequency shall be at least annually in accordance with NFPA-86 or original equipment manufacturer recommendations. Testing is also required after valve disassembly and reassembly for inspection, cleaning or rebuilding.

## OPERATION

**Normally Closed:** Valve is closed when solenoid is de-energized; open when energized.

**NOTE:** No minimum operating pressure differential required.

## INSTALLATION

Check nameplate for correct catalog number, pressure, voltage, frequency, and service. Never apply incompatible fluids or exceed pressure rating of the valve. Installation and valve maintenance to be performed by qualified personnel.

## Temperature Limitations

For valve ambient and fluid temperatures, refer to chart below.

Catalog Number	Catalog Number Prefix	Minimum and Maximum Ambient and Fluid Temperatures
8040C4 8040C5	None or, SC	-40°F (-40°C) to 125°F (54°C)
	HT	-40°F (-40°C) to 140°F (60°C)
8041 or EF8040C4 EF8040C5	None	32°F (0°C) to 125°F (54°C)
	HT	32°F (0°C) to 140°F (60°C)

## Positioning

This valve is designed to perform properly when mounted in any position. However, for optimum life and performance, the solenoid should be mounted vertically and upright to reduce the possibility of foreign matter accumulating in the solenoid base sub-assembly area.

## Piping

Connect piping to valve according to markings on valve body. Apply pipe compound sparingly to male pipe threads only. If applied to valve threads, the compound may enter the valve and cause operational difficulty. Avoid pipe strain by properly supporting and aligning piping. When tightening the pipe, do not use valve or solenoid as a lever. Locate wrenches applied to valve body or piping as close as possible to connection point. Valves should be checked for external leakage at piping connections after installation, see *Testing for External Leakage* section.

**▲ CAUTION:** To avoid damage to the valve body, **DO NOT OVERTIGHTEN PIPE CONNECTIONS.** If **TEFLON\* tape, paste, spray or similar lubricant is used, use extra care when tightening due to reduced friction.**

**▲ CAUTION:** To protect the solenoid valve, install a **strainer or filter, suitable for the service involved, in the inlet side as close to the valve as possible. Clean periodically depending on service conditions. See ASCO Series 8600, 8601 and 8602 for strainers.**

## Testing for External Leakage

**▲ WARNING:** To prevent the possibility of death, serious injury or property damage, **turn off electrical power, depressurize valve, extinguish all open flames and avoid any type of sparking or ignition. Vent hazardous or combustible fluid to a safe area before servicing the valve.**

1. Block gas flow on downstream side of valve.
2. Apply pressure to valve within nameplate rating and energize solenoid.
3. Apply a soapy solution or a commercially available leak detecting solution to the pipe connections and check for bubbles. If the valve has been tested for seat leakage or disassembled and reassembled for inspecting, cleaning, or rebuilding apply the solution around solenoid base sub-assembly, bonnet/body joint and pipe plugs.

\*DuPont's Registered Trademark.

**ASCO**<sup>®</sup>

MMIII

All Rights Reserved.

Printed in U.S.A.

Page 1 of 4

4. If leakage exists, depressurize valve and turn off electrical power supply. Tighten connections as required and retest following the above steps.

## MAINTENANCE

**▲ WARNING: To prevent the possibility of severe personal injury or property damage, turn off electrical power, depressurize valve, extinguish all open flames, and avoid any type of sparking or ignition. Vent hazardous or combustible fluid to a safe area before servicing the valve.**

NOTE: It is not necessary to remove the valve from the pipeline for repairs.

### Cleaning

All solenoid valves should be cleaned periodically. The time between cleanings will vary depending on the medium and service conditions. In general, if the voltage to the coil is correct, sluggish valve operation, excessive noise or leakage will indicate that cleaning is required. In the extreme case, faulty valve operation will occur and the valve may fail to open or close. Clean strainer or filter when cleaning the valve.

### Preventive Maintenance

- Keep the medium flowing through the valve as free from dirt and foreign material as possible.
- Periodic exercise of the valve should be considered if ambient or fluid conditions are such that corrosion, elastomer degradation, fluid contamination build up, or other conditions that could impede solenoid valve shifting are possible. The actual frequency of exercise necessary will depend on specific operating conditions. A successful operating history is the best indication of a proper interval between exercise cycles.
- Depending on the medium and service conditions, periodic inspection of internal valve parts for damage or excessive wear is recommended. Thoroughly clean all parts. If parts are worn or damaged, install a complete rebuild kit.

### Causes of Improper Operation

- **Incorrect Pressure:** Check valve pressure. Pressure to valve must be within range specified on nameplate.
- **Excessive Leakage:** Disassemble valve and clean all parts. If parts are worn or damaged, install a complete ASCO Rebuild Kit.

### Valve Disassembly (Refer to Figure 2)

1. Disassemble valve in an orderly fashion. Use exploded view for identification and placement of parts.
2. Remove solenoid enclosure, see separate instructions.

3. Unscrew solenoid base sub-assembly from valve bonnet.
4. Remove bonnet screws, valve bonnet, solenoid base gasket, body gasket and core sub-assembly with core spring, core guide and rider ring attached.
5. All parts are now accessible for cleaning or replacement. Replace worn or damaged parts with a complete ASCO Rebuild Kit.

### Valve Reassembly

1. Lubricate all gaskets with DOW CORNING® 200 Fluid lubricant or an equivalent high-grade silicone fluid.
2. Replace body gasket, core sub-assembly with core spring, core guide and rider ring attached.
3. Replace valve bonnet and bonnet screws, hand thread screws into valve body as far as possible. Then torque bonnet screws in a crisscross manner to  $110 \pm 10$  in-lbs [ $12,4 \pm 1,1$  Nm].
4. Replace solenoid base gasket and solenoid base sub-assembly. Torque solenoid base sub-assembly to  $45 \pm 5$  ft-lbs [ $61,1 \pm 6,8$  Nm].
5. Replace solenoid, see separate instructions.

**▲ WARNING: To prevent the possibility of death, severe injury or property damage, turn off electrical power, depressurize valve, extinguish all open flames and avoid any type of sparking or ignition. Vent hazardous or combustible fluid to a safe area before servicing the valve.**

6. Check valve for external leakage as indicated under the *Piping* section, and for internal (seat) leakage as follows.

### Testing for Internal (Seat) Leakage

**▲ CAUTION: Be sure valve can be tested without affecting other equipment.**

1. Using a 3/16" hex key wrench, remove the 1/8" pipe plug from the downstream side of the valve body. Then install suitable test piping (e.g.; two short nipples and an elbow or tubing) to check for leakage.
2. Block flow downstream of valve.
3. Restore electrical power supply and pressurize valve to nameplate rating.
4. With valve de-energized, immerse end of test piping in a cup of water for 20–30 seconds and look for bubbles, which would be indicative of seat leakage. Repeat this procedure at several progressively lower pressures, down to approximately 1/4 psi. Between each test, remove cup of water and operate valve.
5. If seat leakage is detected, turn off electrical power and depressurize valve. Disassemble and check for proper placement of parts, or any foreign matter that may have entered the valve. Clean as necessary, reassemble and re-test valve for both external and internal leakage.

## ORDERING INFORMATION

### FOR ASCO REBUILD KITS

6. If no seat leakage is detected, remove test piping. Apply a small amount of Loctite Corporation's PST® Pipe Sealant 567 (or equivalent) to the pipe plug threads. Reinstall the pipe plug and tighten securely.
7. Test for external leakage as described in *Piping* section.
8. When maintenance is complete, operate the valve a few times to be sure of proper operation. A metallic *click* indicates the solenoid is operating.

Parts marked with an asterisk(\*) in the exploded view are supplied in Rebuild Kits. When Ordering Rebuild Kits for ASCO valves, order the Rebuild Kit number stamped on the valve nameplate. If the number of the kit is not visible, order by indicating the number of kits required, and the Catalog Number and Serial Number of the valve(s) for which they are intended.

### Partial side view of valve body showing location of tapped and plugged holes for pressure and seat leakage testing

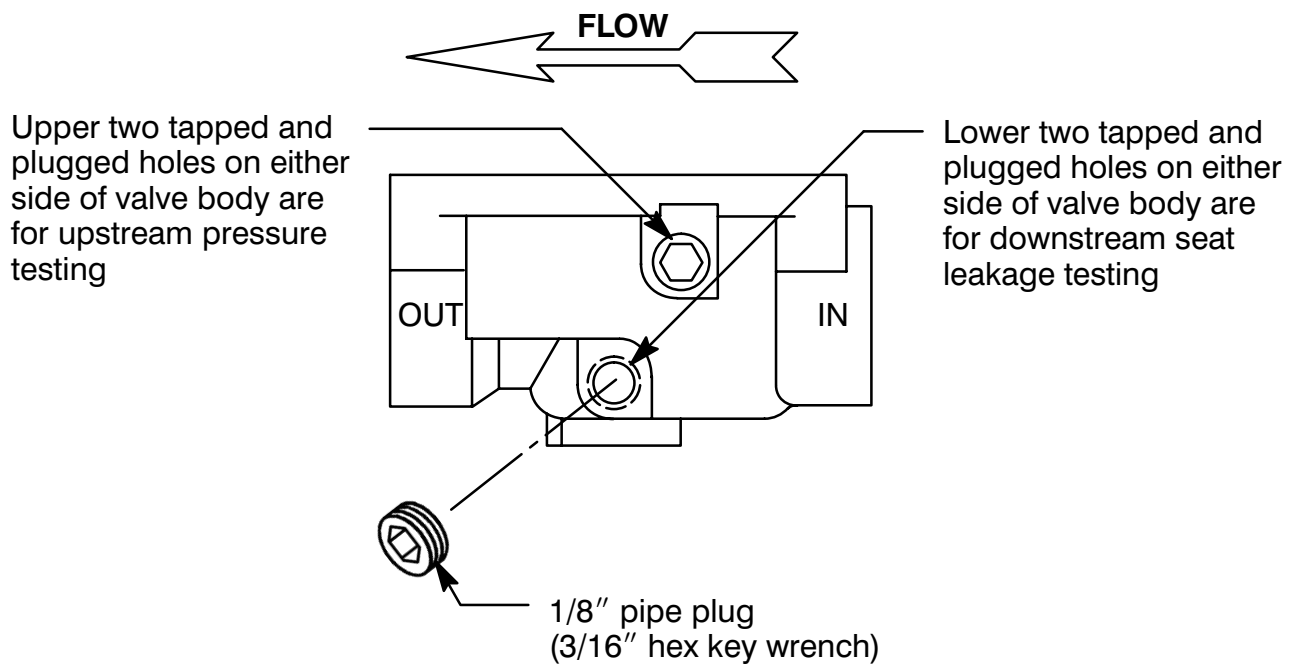

Figure 1. Provisions for pressure and seat leakage testing.

### Torque Chart

Part Name	Torque Value	Torque Value Newton–Meters
bonnet screws	110 ± 10 in–lbs	12,4 ± 1,1
solenoid base sub–assembly	45 ± 5 ft–lbs	61,1 ± 6,8

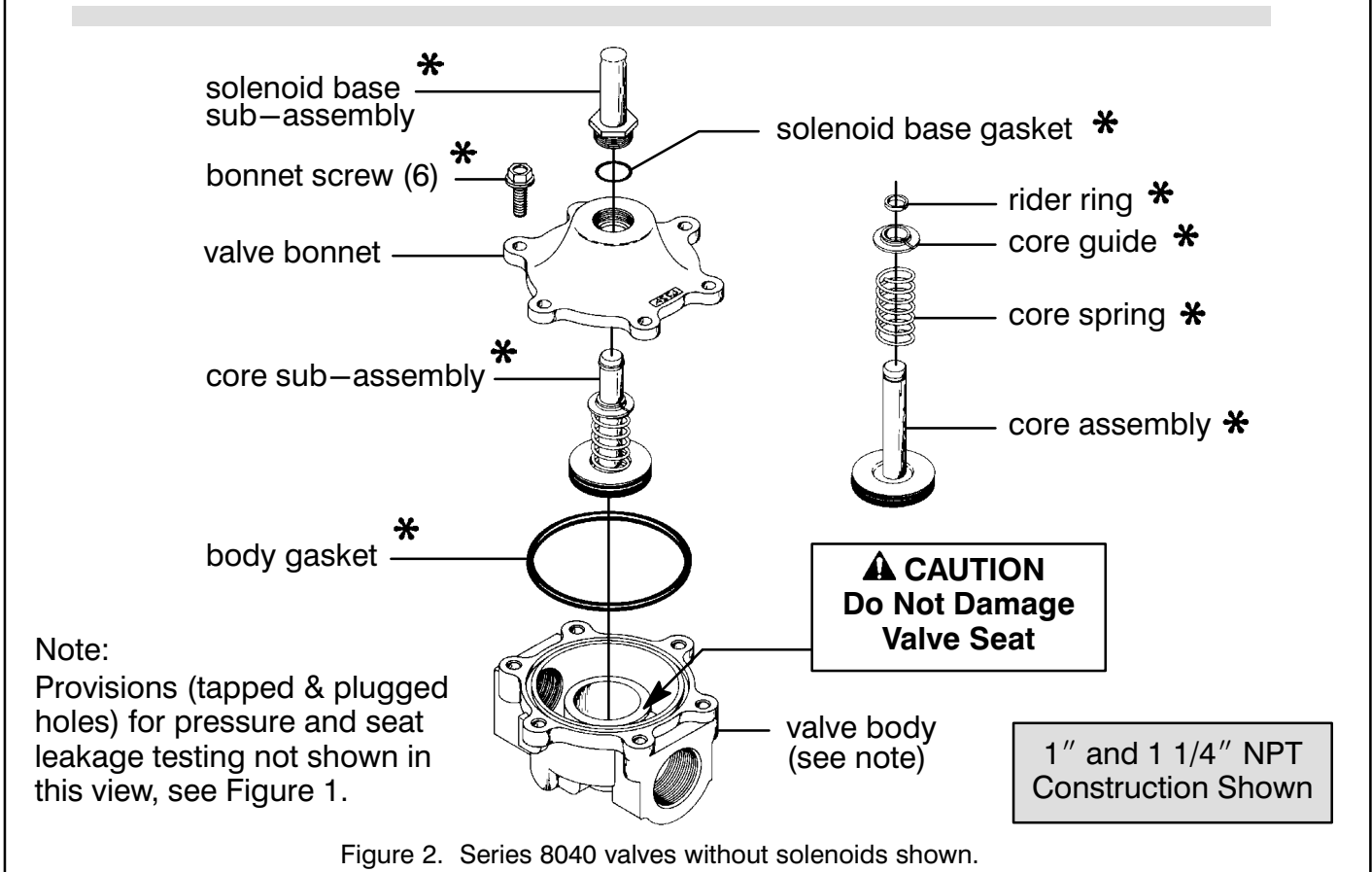
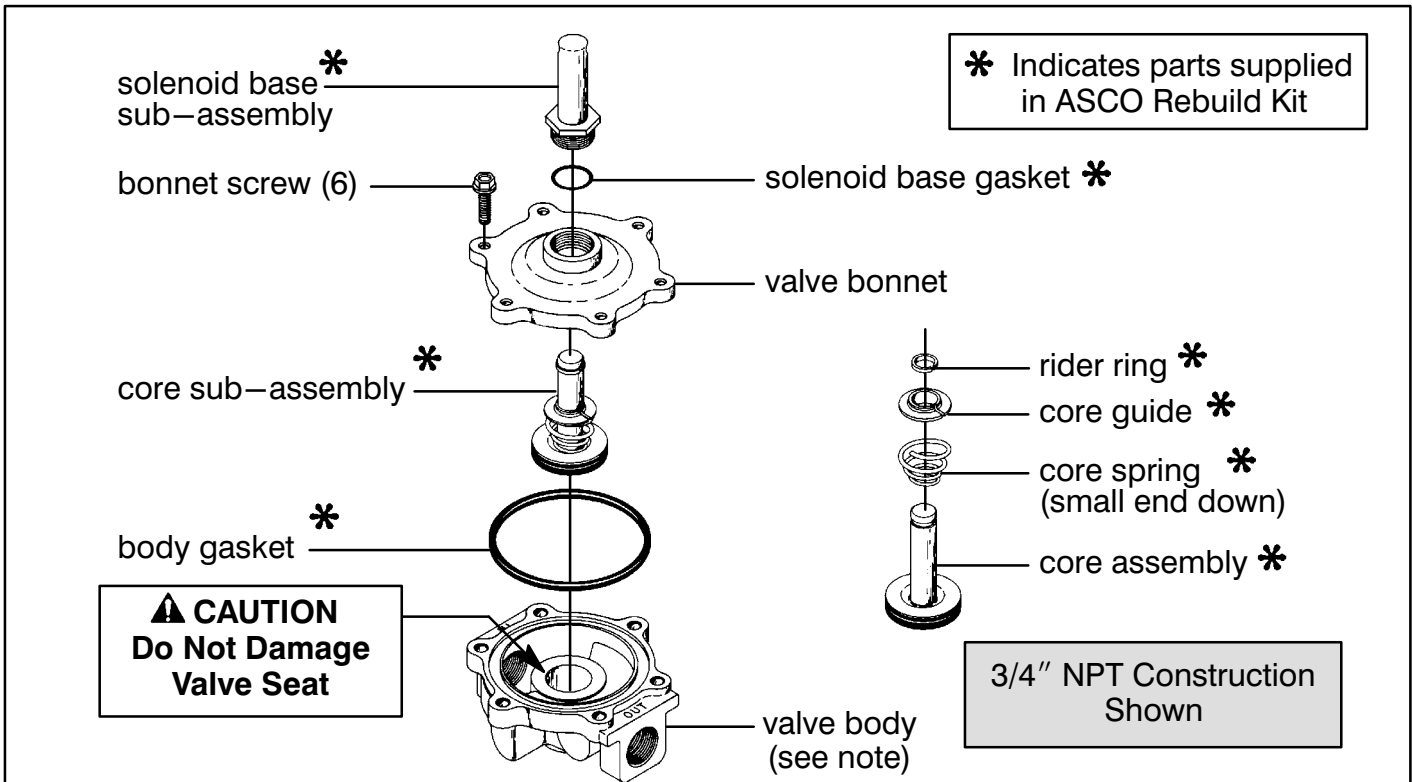

Figure 2. Series 8040 valves without solenoids shown.